

● OUTLINE DIMENSION

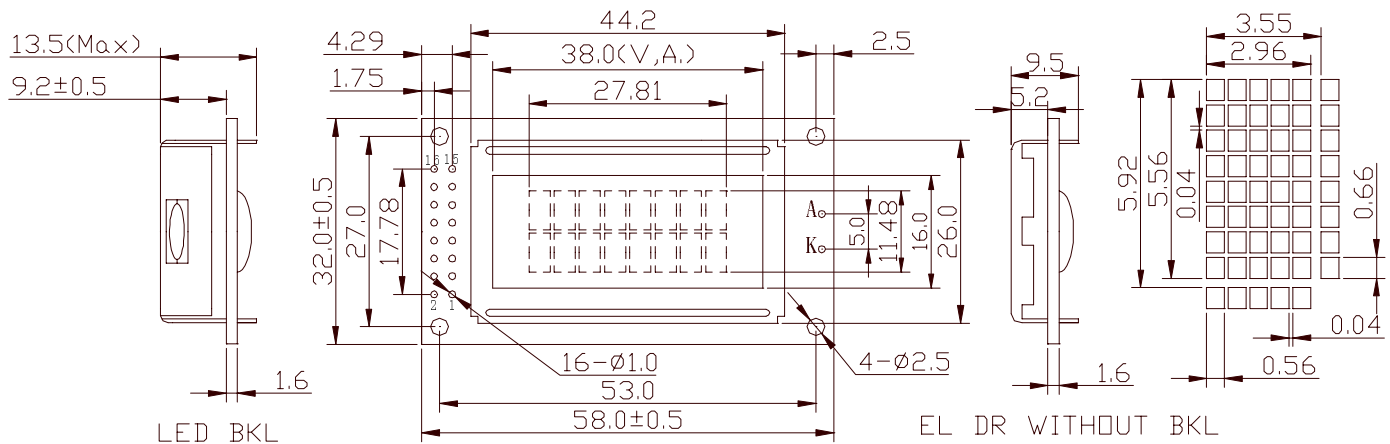

● BLOCK DIAGRAM & POWER SUPPLY

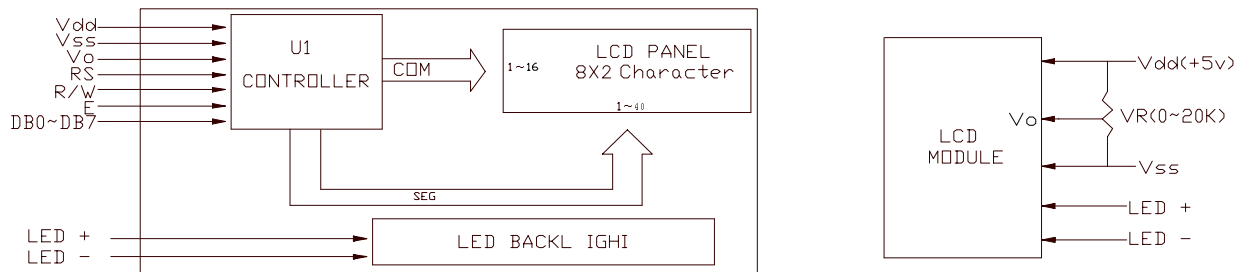

● MECHANICAL SPEC.&FEATURES

Item	Dimension(mm)
Module Size(WxHxT)	58.0x32.0x9.5/13.5
Viewing Area(WxH)	38.0x16.0
Dot Size(WxH)	0.56x0.66
Dot Pitch(WxH)	0.60x0.70
Character Size (WxH)	2.92x5.56
Character Pitch(WxH)	3.55x5.92

Features	
LC Fluid	TN,STN(Yellow-green,Gray,Blue),FSTN
Polarizer	Reflective,Transflective,Transmissive
View Angle	6:00 o'clock or 12:00 o'clock
Display Type	Positive or Negative
Backlight	LED(Optional)
Operating Temp.	0°C ~ 50°C or -20°C ~ 70°C
Controller	S6A0069 or Equivalent

● INTERFACE PIN CONNECTIONS

in No.	Symbol	Function
1	V _{ss}	Ground for logic
2	V _{dd}	Power supply for logic
3	V _o	Power supply for LCD
4	RS	Register selection(H:Data,L:Instruction)
5	R/W	Read/Write selection(H:R,L:W)

Pin No.	Symbol	Function
6	E	Enable signal
7~14	DB0~DB7	Data bus lines
15	A	BKL+
16	K	BKL-

● ELECTRICAL CHARACTERISTICS

Item	Symbol	Test Condition	Min	Typ.	Max.	Unit
Operating Voltage	V _{dd}	T _a =25°C	...	5.0	...	V
Operating Voltage for LCD	V _{lcd}	T _a =25°C	...	4.5	...	V
Supply Current	I _{dd}	T _a =25°C, V _{dd} =5.0V	...	2.0	3.0	mA
Supply Voltage for LED	V _f	T _a =25°C, R=6.8Ω	...	4.2	...	V
Supply Current for LED	I _f	T _a =25°C, V _f =4.2V	mA